

# POGLAIN MAG

#9 June 2017



**SPECIAL EDITION  
ELMIA WOOD 2017**

**JOIN US**

**BOOTH  
892B**



# CONTENTS

---

- |           |   |           |   |
|-----------|---|-----------|---|
| <b>4</b>  | <b>THE PROCESS ROLLER DRIVE</b>   | <b>16</b> | <b>CBI</b><br>Log & Stump Screw   |
| <b>5</b>  | <b>HIGH FLOW™</b><br>To Meet The Needs Of<br>The Forestry Market                | <b>18</b> | <b>IWAFUJI INDUSTRIAL Co., Ltd</b><br>High Flow MS Motors                     |
| <b>6</b>  | <b>BRUKS</b><br>MS Motors For Mobile Chippers                                   | <b>20</b> | <b>SEIK Srl</b><br>Winch Motorization   |
| <b>7</b>  | <b>WÜST MASCHINEN UND<br/>FAHRZEUGBAU AG</b>                                    | <b>21</b> | <b>TAJFUN</b><br>A Compact Solution For<br>The MOZ Tower Yarder               |
| <b>8</b>  | <b>BRUNO INDUSTRIAL</b><br>A Selector Valve In<br>A Wood Chipper                | <b>22</b> | <b>ECO LOG</b><br>A High Performing Travel Drive<br>For Harvesters Harvesters |
| <b>9</b>  | <b>PRO JERNAC</b><br>Forestry Trailer Assist                                    | <b>24</b> | <b>CAM-LOBE MOTORS</b><br>THE Solution For Slewing Drives                     |
| <b>10</b> | <b>ADDIDRIVE ASSIST</b><br>On Trailer   | <b>25</b> | <b>DIRKER</b><br>2DLH Log Handler   |
| <b>12</b> | <b>ADDIDRIVE FOR TRUCK</b><br>A No-Compromise Solution<br>For Timber Transport! | <b>26</b> | <b>HITTNER</b><br>Skidder Brake Valves  |



# EDITORIAL



**JAN LINDSTROM**  
SCANDINAVIA AREA  
SALES MANAGER

**«Poclain Hydraulics mission is to be the first choice in forestry and we will continue our efforts to deliver products with high performance.»**

Poclain Hydraulics has become a market leader in forestry over the last 20 years.

Poclain Hydraulics motors were first used in single grip harvester heads, in order to drive tree processing rollers. Key success factors have been their robustness, their ability to sustain short but very high power peaks, and their consistently high efficiency over time. These factors allow for extremely frequent and accurate starting and stopping cycles for higher productivity, a key driver when it comes to “cut to length” tree technology.

Additional uses of Poclain Hydraulics products can be found on harvesters’ crane and cabin swing drive, where the precision and high torque of Poclain Hydraulics motors allow for the elimination of gear boxes and back lash. These motors are able to deliver the required torque when machines need to work in difficult conditions, such as very steep slopes. In these applications there has been cooperation with several customers including: Komatsu, Ponsse and Eco Log or Menzi Muck.

Some other customers have also used our wheel motors for travel drives to propel single wheels or bogies of harvesters, such as Rottne and Eco Log in Sweden. This machine architecture is unbeatable when it comes to climbing over rocks, an obstacle that is frequently encountered in the Scandinavian forests.

The latest improvements at Poclain Hydraulics have focused on areas such as weight reduction, higher flow capabilities, reduced pressure drops, increased life time and durability. Through these benefits, we are proud to bring our small contribution to the progress of such a demanding, innovative and fascinating industry !





# THE PROCESS ROLLER DRIVE

Poclair Hydraulics has been for several years the leading supplier of feed roller motors for single grip harvester heads. As supplier for almost all producers of harvester heads Poclair have created a vast portfolio of motors optimized for all sorts of applications.



**MS05 AND MS08**  
are the most popular motor  
sizes for heads

At the end of the forestry harvester crane a harvester head is attached to grip, cut and fell trees. The tree is repeatedly fed by feed rollers through delimiting knives and cut in specified length. This is called Cut to Length (CTL) harvesting. Another method is Full Length harvesting (FL), when the tree is only cut, felled and delimited, without cutting in lengths. PH motors are in both cases used to drive the feed roller motors.

The modular design of the Poclair came lobe motor together with a catalogue of options makes it possible to adapt and optimize the motors for the different sizes and designs of the harvester head. This is the reason you find the Poclair motor on small thinning head with MSE02 displacement 332 cc up to huge final felling heads MS18 with 1650 cc motors. The feed roller motor has to handle quick acceleration and stop at precise position for accurate cutting length. The handling of the harvester head, swinging freely at the end of the crane, cause hard hitting of the trees or the ground which result in mechanical shocks. On top of that the harvester heads are used in all climates, from coldest winter to tropical heat.

Cuttings from the tree and chain oil used for chain saw are very aggressive and the hydraulic power peaks can be severe.

Years of experience are built in the Poclair motors to withstand the demanding challenges and prolong the life time of the motors. New material and technology as well as smart adaptation have shaped a very robust motor designed for forestry.

Since the applications include trees like hard wood as well as pine, spruce and eucalyptus the need of both torque to delimit and speed are of high importance. The compact design of the Poclair motor together with high starting torque allows the designer of the harvester head to reduce weight as well as dimensions and still have the force to delimit efficiently. Poclair Hydraulics continuously invest in R&D and the most recent evolution HighFlow™ motor has now been introduced with a new distribution technology reducing pressure losses by over 50% and increasing efficiency over the entire operating range. All benefits for the user with fuel savings, increased speed generating more cubic timber per hour.



# HIGH FLOW™

## To Meet the Needs Of The Forestry Market

Reliability and productivity are probably the two major concerns of the manufacturers of machines and tools for the forestry and associated applications. The daily challenge is to push the performance limits of these machines and tools while taking into account their mass.

Poclain Hydraulics keeps innovating to offer more and more powerful products to meet market requirements, and for our customers in the forestry markets this innovation takes the form of the new HighFlow™ range of motors.

HighFlow™ motors incorporate a new distribution technology to reduce pressure losses by over 50%, thereby increasing efficiency over the entire operating range. Reducing pressure losses helps to optimize the whole vehicle transmission, opening the way to downsizing. This type of distribution also allows us to extend the attainable speed limits. For example, the 376 cm<sup>3</sup> MS05 motor offers an hitherto unattainable maximum rotation speed of 520 rpm. This speed performance is twice that of a standard motor. Users also like the fast and smooth displacement shifts and rotation reversal.

These innovations, provide new performance for machines and tools.

Innovation is not restricted to the distribution of these motors - component parts have also been made more robust to withstand even heavier-duty applications.

HighFlow™ motor bearing supports take a high load, and they are sealed to cope with the forestry market working conditions.

The modularity of these motors allows, as with conventional ones, to propose a motor adapted to each application.

Poclain Hydraulics - your prime partner for success.

**Maximum  
Speeds +50%**

A HighFlow™ motor can reach higher speeds with the same pressure drop.

**Pressure  
Drop -50%**

At an equivalent speed, a HighFlow™ motor reduces pressure drops.





# BRUKS

## MS Motors For Mobile Chippers

Bruks Mobile Chippers Division from Sweden designs, manufactures and sells mobile chippers. The chipper units can be installed on trucks, forwarders or trailers. Bruks product portfolio contains mobile chippers where Poclain Hydraulics motors are used to drive and power the chippers infeed system.



**THE MOBILE CHIPPERS** are equipped with MSE18 for upper infeed rollers and MSE05 for the lower infeed rollers

Bruks is committed to supplying customers active in bioenergy markets with innovative technology solutions to produce renewable energy with a high degree of purity, perfectly-adapted product size and low-moisture content.

Bruks has worked closely with Poclain Hydraulics in order to produce a high-density product (in the form of chips) and significantly minimize energy losses and costs. Poclain Hydraulics' cam-lobe motor was chosen due to its high torque and compact design. The chipper drum is driven by the diesel engine and the hydraulic motors are used as a power source for the chipper's infeed rollers.

In order to have a good starting torque for the infeed rollers the hydraulic direct drive ensures a reliable drive solution. The concept of the mobile chipper is to chip branches and logs up to 60 cm in diameter, which is challenging for the infeed motors that not only feed at a constant speed but also have to withstand the heavy shocks generated by the drum and vibrations.

The product chosen was the MSE18 motor for the chipper's upper infeed. It is equipped with an integrated speed sensor for an excellent speed regulation.

An infeed table with rollers is used to move the branches and logs into the chipper's drum. The lower infeed rollers are powered by one or alternatively two MSE05 motors. These motors are also equipped with a speed sensor for excellent speed regulation.

Chipper applications are always critical due to the fast variation in torque. Poclain Hydraulics' vast experience with this type of application means that our hydraulic cam-lobe motors are well adapted for this demanding application.

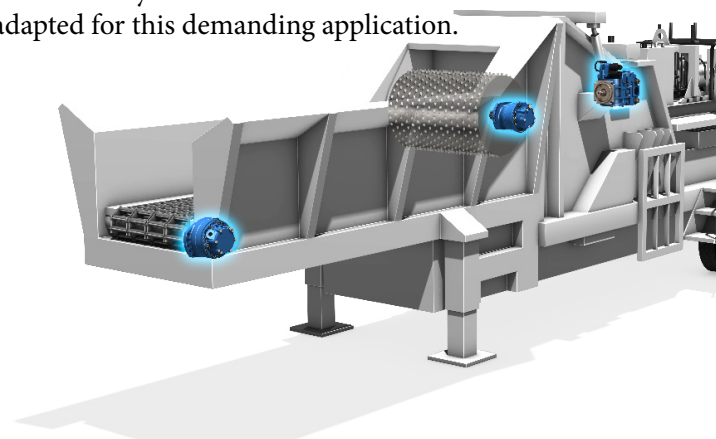



# WÜST MASCHINEN UND FAHRZEUGBAU AG

The company Wüst Maschinen und Fahrzeugbau AG, located in CH-3537 Eggiwil, is a major producer of wood chippers. They were founded in 1977 by Mr. Karl Wüst as a repair shop for agricultural equipment. In 1997, they built their first wood chipper as an OEM.

The chipper drums have always been mechanically driven, but the feed drums were hydrostatic from the beginning. They used gearbox drives for the first machines. Then Kurt Hess from Hawe-Hydratec (the Poclain Hydraulics distributor for Switzerland) recommended the usage of Poclain Hydraulics motors instead. The compact design and shorter length allowed Wüst more freedom to optimize the machine design.

Today the portfolio is comprised of pulled behind and truck-mounted machines with chipper units that are powered from 200 HP to more than 600 HP.

Customers are located in neighboring countries, but can be found as far as Russia as well.

The main key to success is a rugged and reliable design, but the chip quality is an important criterion for the customers as well. It influences the burning behavior in the power plants and heating systems. The machines must also be safe and user friendly for the operators.

Design engineer, Martin Schüttel, confirmed the suitability of the Poclain Hydraulics motors for this application. The long life time has been proven over the years, even with the bio-fluids used. Also, there is no extra maintenance necessary due to the direct drive principle (no gear-box oil).

Wüst is very satisfied with the logistics support from Hawe-Hydratec.





# BRUNO INDUSTRIAL

## A Selector Valve In A Wood Chipper

Bruno Industrial is the leader in wood chipper technology in Brazil. Based in Santa Catarina State, Bruno manufactures a large number of machines for wood, forest and recycling industry.



Poclain Hydraulics started working with Bruno showing them the potential of the valve 3V2H20 in the integration with their system. This valve equips a wood chipper named Forest Predator and is responsible for diverting the flow from the tracks to the tools and from the tools to the track.

Poclain Hydraulics valve was chosen among their local valves suppliers due to high pressure capability (up to 450 bar), high flow and also customer service support.

Bruno Industrial is the leader in wood chipper technology in Brazil. Based in Santa Catarina State, Bruno manufactures a large number of machines for wood, forest and recycling industry.



# PRO JERNAC

## Forestry Trailer Assist

Pro Jernac is a young enthusiastic mod-shop specializing in servicing forestry machines from skidders to excavator-mounted harvesting heads. The Slovenia-based company has recently moved into new bigger facilities to be able to support the demand of the market.



Štefan Tompa and his team have developed their first completely own project: a forestry trailer. Štefan's idea was to be able to transport the logs where no other can, essentially this means from the top of the hill to the valley. To succeed in this mission, they needed heavy-duty hydraulic assistance for this high-end machine.

The HD22184 trailer can cross rough terrains with its main advantage being hydrostatic braking when driving fully loaded downhill, additionally it can steer the bogie axles for better maneuverability in the forest.

Poclair Hydraulics has developed the hydraulic trailer assist for Pro Jernač using:

- New heavy duty PW closed-loop pump;
- Radial piston motors MSE18;
- Newly designed heavy duty flow divider FD-H;
- Free-wheeling valve VDF;
- KVM open-loop bankable block for auxiliary functions (e. g. steering of bogie axles);
- On-board electronics including customized software for the complete control of the trailer assist from the tractor's cabin.

The tractor equipped with the HD22184 trailer is rivaled only by the effectiveness of a dedicated forestry forwarder; on the other hand the investment required for a dedicated forestry forwarder is far greater than that of the HD22184 trailer.

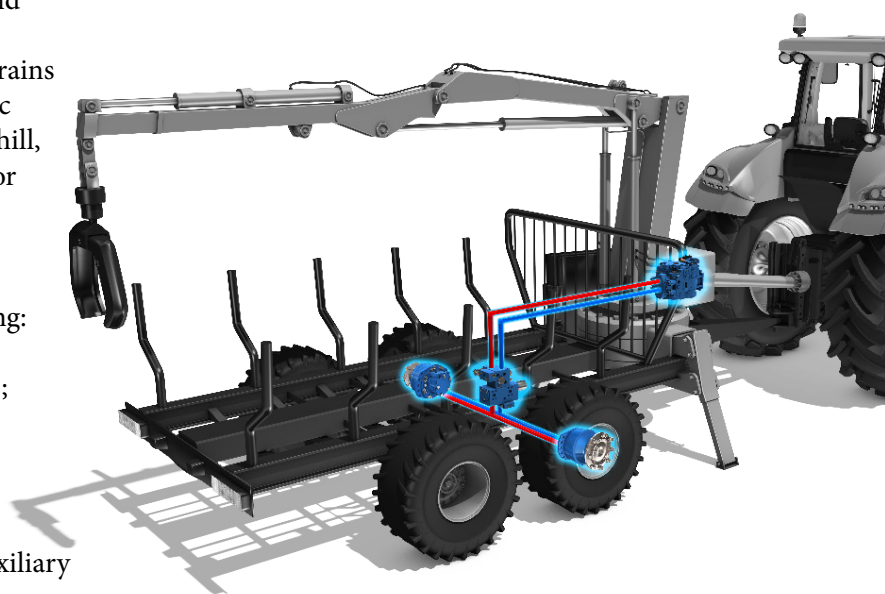

**THE HD22184 TRAILER**  
equipped with the  
Poclair hydraulics assist

# ADDIDRIVE ASSIST

## On Trailer

Some trailers, pulled by farm tractors and heavily loaded, are used for intensive work on ground with very variable surface grip conditions. This mainly applies to forestry trailers, dump trucks used for excavation work, or agricultural pulled behind sprayers used on hilly fields.

Under these conditions, the use of bigger and more powerful tractors does not help to solve the problem, with the tractive effort being limited by the grip of the machine's tires and the load applied to each of its axles. It is the weather that determines what work is to be carried out, with financial consequences and delays on the work site being at stake. So, herein lies the problem.

One solution consists in adding to the trailer a drive system that uses hydrostatic transmission. This addition to the tractive effort is activated at the request of the driver and is available for speeds up to 15kph; above this, the system automatically disengages. The mechanical losses linked to the system are therefore minimal when driving on roads at the maximum authorized speed of 40 kph. Furthermore, when the system is in gear, the «engine brake» effect generated by the hydrostatic transmission helps to retain the tractor when moving downhill. This automatic deceleration prevents the driver from operating the friction brakes. The convoy's safety is optimal.

### Poclair's Addidrive Assist solution consists of:

- a PM50 closed loop hydraulic pump driven by the tractor's mechanical or hydraulic power take-off.
- two MSE18 «low speed high torque» high-efficiency hydraulic motors installed in one of the trailer's axles, with free-wheeling capability.
- a hydraulic valve controlling the power to the two motors depending on the needs and speed of the convoy.
- a relay box or SD-CT30 control unit (for the «electronic management» option) providing management of the system using data from the hydraulic motors, the service brake control and the oil temperature.

Through its architecture, the system is completely independent from the tractor's hydraulics. Hence, the trailer's drive system performances are guaranteed whatever the characteristics of the towing vehicle used.

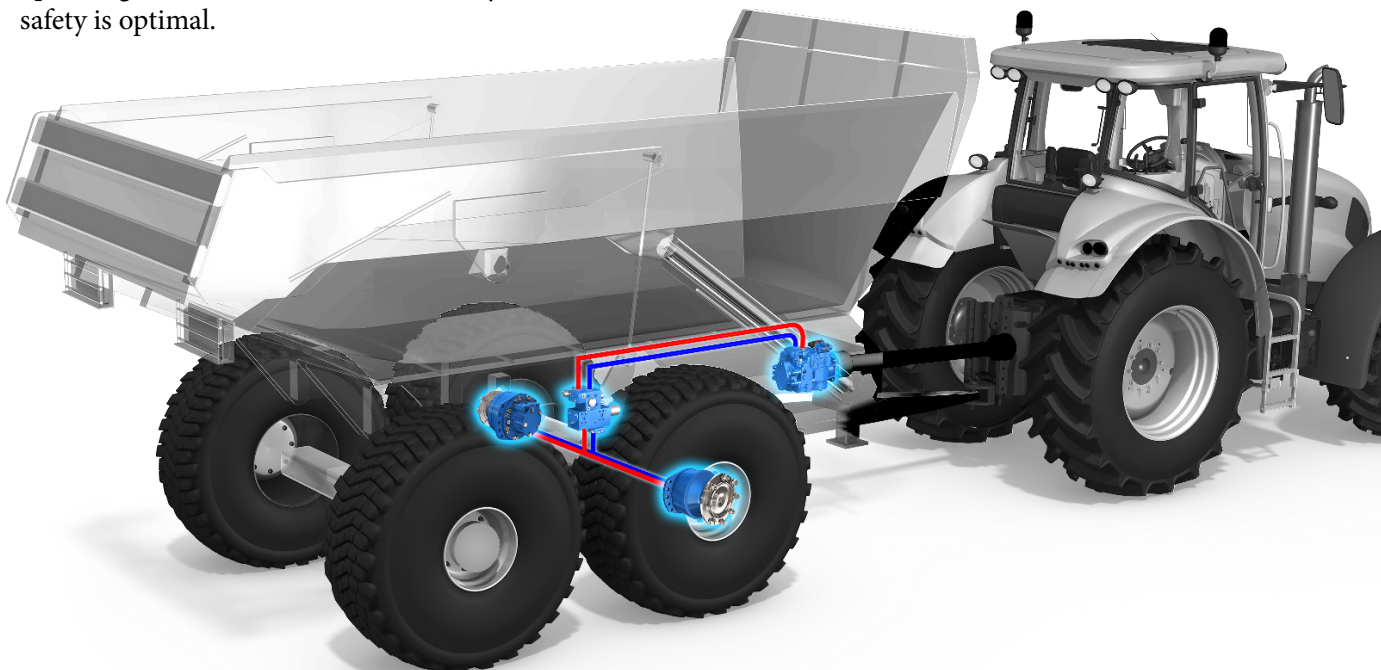



The closed loop pump fitted to the trailer and used in place of the tractor's hydraulics, helps to provide a maximum pressure of 400 bars in the system as well as the «engine brake» retaining effect. The high pressure hydraulic motors may then be used to their full torque potential. One single drive axle is sufficient, whereas the use of the tractor hydraulics, limited to 250 bars, would require two drive axles. Finally, there is no possible risk of oil pollution (no risk to mix tractor oil with closed loop trailer oil), since the only connection between the tractor and trailer is the mechanical or hydraulic power take-off.

### The Addidrive Trailer Assist systems' offer is two-tiered:

- Addidrive Assist «Entry» for the occasional need for help and easy set-up on the trailer.
- Addidrive Assist «Medium» for intensive use of the system and for making the best possible use of the transmission options via electronics.

The Poclair Addidrive Assist system in its «Medium» version is currently fitted to the Hardi-Evrard's pulled behind Meteor 6x6 sprayer as well as to the DTP-21 public works tipper from the French manufacturer Delaplace.

#### MSE18 MOTOR installed in the trailer's axle



# ADDIDRIVE FOR TRUCKS

## A No-Compromise Solution For Timber Transport

In forestry work, the two main transport applications using trucks are categorized depending on the area where they are able to load timber: by the roadside or directly where the timber is felled in the forest. The two loading types involve debarked logs or round timbers.

Regulations authorize up to 57 tons GVW for 6 axles or more but the maximum load authorized on the axles must comply with the regulations in force for all road transport.

Typical architectures include:

- **4x2 or 6x4 tractors + various trailer configurations:**  
2 or 3-axles semi-trailer or detachable trailer carried on the tractor when the convoy is travelling unloaded

- **6x4 carriers + 3-axles trailer with fore-carriage:**  
Often a crane installed behind the tractor cab or at the back of the carrier enables independence of the convoy for loading.

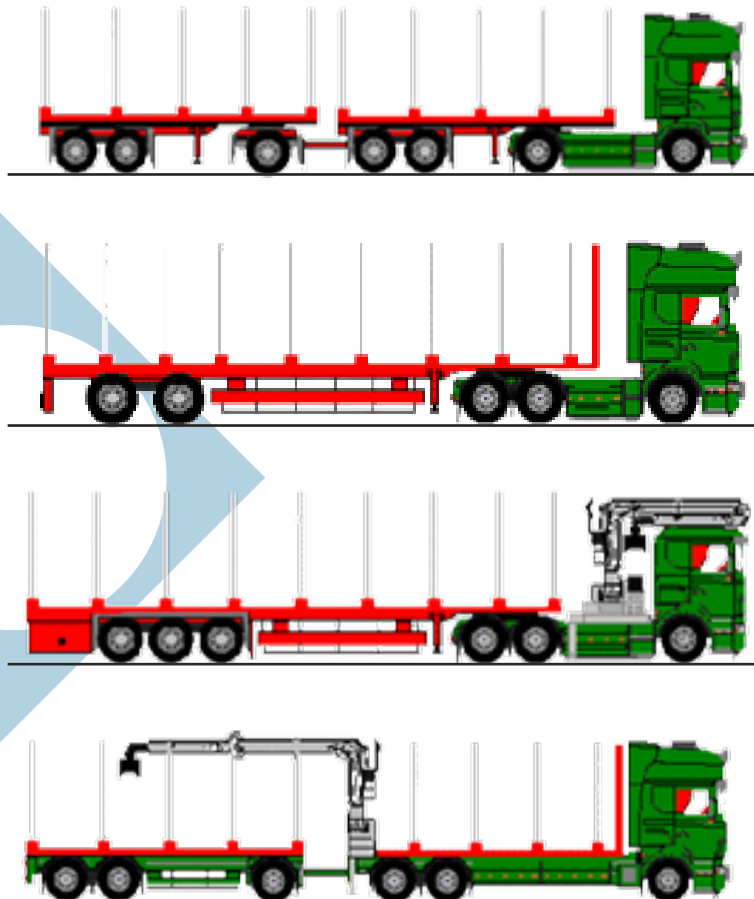

From <http://formation-transport-routier.fr>, Jean-Pierre Laffitte ©





**TRUCK**  
equipped with  
MFE08 motor in  
the front axle

**For loading by the roadside,** trucks are favored that can travel on secondary or main roads. The main qualities expected are a maximum transported load (around 22.5t), reasonable fuel consumption (the annual mileage is about 100 000 km) and a spacious and comfortable cab, since the driver often has to sleep in it.

**For loading in the middle of the forest,** which has the advantage of reducing the skidders' hauling effort, trucks are selected that are more compatible with winding roads and have high haulage capacity on unstable ground. In practice, to guarantee they never get stuck, these trucks are fit with several drive axles and short rear axle ratios. But this

limits the maximum speed, tends to increase fuel consumption and affects the payload. Furthermore, the wheel base is often shorter to help with maneuvers.

The market offers excellent solutions suitable for either loading type and maximize uptime, but there is no classic solution enabling the convoy to load both at the forest edge and in the middle of the forest. Bigger traction capacities always means compromise, reducing the multi-use efficiency and increasing operating costs.

# Poclain Hydraulics Solutions

Poclain Hydraulics has developed a range of solutions which is now well-known in the truck industry in Europe and the United States: Addidrive Technology. It enables the traction capacity to be maximized with a loss of payload of less than 450 kg and hardly any impact on fuel consumption, whilst improving the maneuverability and maintaining driver comfort and safety.

The graph below compares the performances of standard trucks with AWDs and highlights the benefits of our technology:

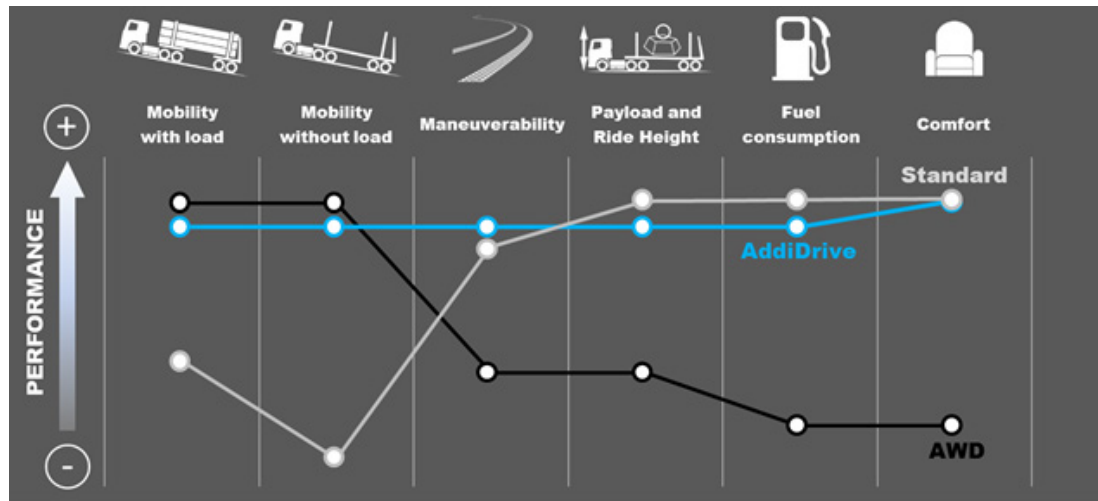

traction on the front axle; as a result the turning radius is reduced by around 10% compared with a standard truck. These benefits are provided without compromising the road-running qualities: fuel consumption remains almost the same (+1 to 2%), the height of the chassis is not affected and the system is compatible with the drive trains designed for long journeys.

Furthermore, this solution, which supports Poclain Hydraulics' reputation for reliability, guarantees performance sustainability for

For forestry applications, the 6x6H configurations - carrier or tractor - are ideal: two hydraulic motors are integrated in the front steering axle. Any loss in drive capacity in the rear mechanically driven axles is automatically compensated by a transfer of torque to the front. A pump driven by a combustion engine PTO, sends oil under high pressure to the hydraulic motors situated in the front wheels as soon as the speed between the front and rear axles starts to vary (which happens when the rear axle(s) start(s) to slip). The system is activated by the driver and disengages automatically above 30 kph.

This solution is highly effective and appreciated by drivers, even the most experienced: it helps to increase the traction capacity to guarantee driving along tricky routes and to climb up muddy or snowy slopes. Maneuvers are facilitated because of the

the lifespan of the truck and does not require any special maintenance in addition to the conventional maintenance program.

To summarize, the main benefits of the Poclain Hydraulics Addidrive solutions for timber transport applications are: **uptime, payload, multi-purpose and safety**. An efficiency pledge that enables the extra costs to be turned into profit in only a few months with this option available at most of the major truck manufacturers.

For further information, please consult our website [www.poclain-hydraulics.com](http://www.poclain-hydraulics.com) or contact us via email at [truckandbus@poclain.com](mailto:truckandbus@poclain.com)



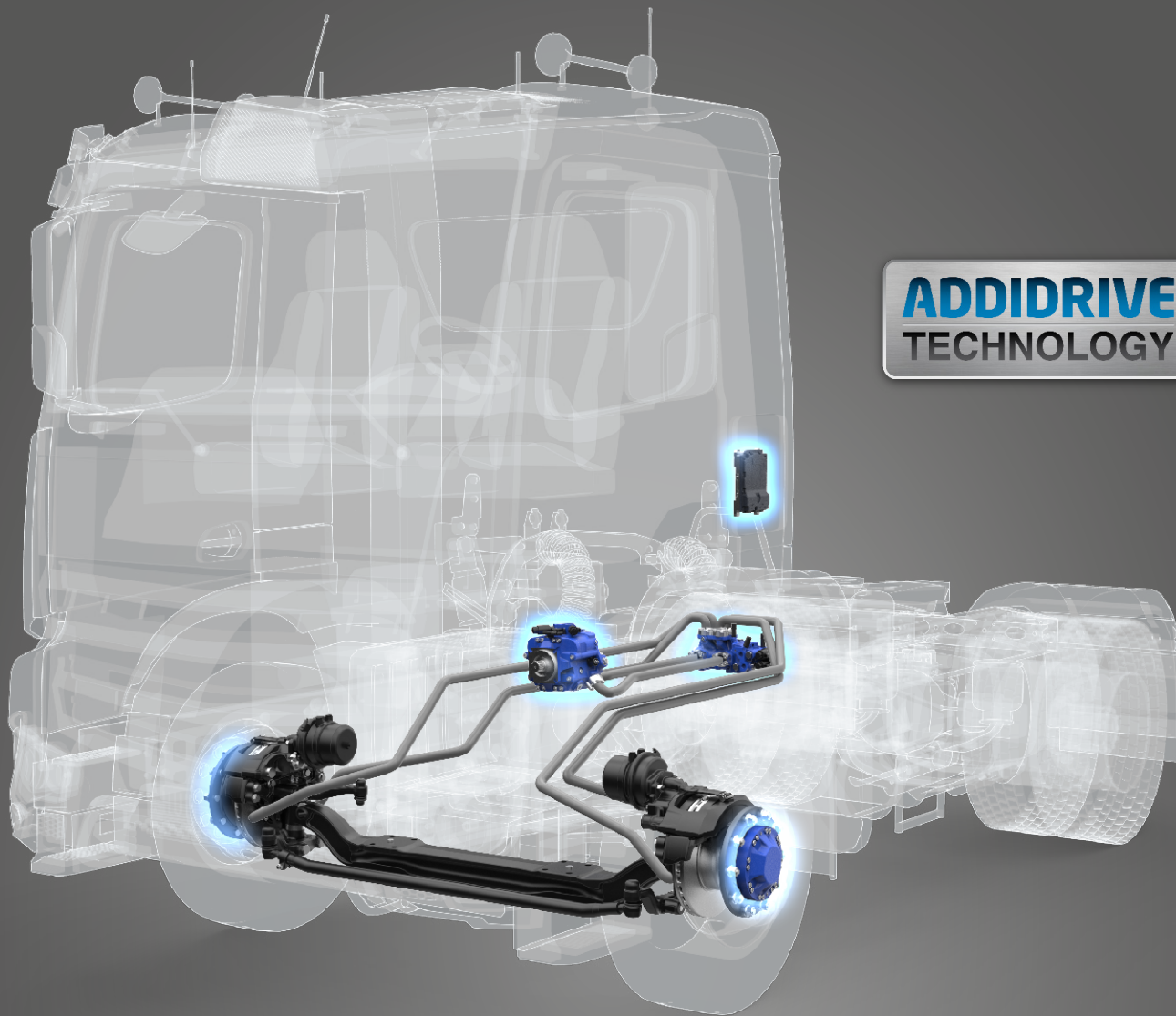

**ADDIDRIVE  
TECHNOLOGY**

**MF hydraulic motors**

**Driven hydraulic axle**

Fitted on the front wheels, the MF motors provide traction or retaining torque whenever needed.

- Up to 82 kW [110 HP] and 12 000 N.m [8,850 lb.ft] per axle
- Up to 30 kph [18.6 mph] when the system is activated

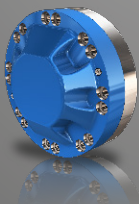

**PW variable displacement pump**

Powered by the internal combustion engine PTO, the PW pump generates and provides hydraulic power to the MF motors

- 96 cm<sup>3</sup> / rev. [5.86 in<sup>3</sup> / rev.]
- Up to 233 kW [312 HP]
- Up to 3 650 rpm
- Up to 450 bar [6,527 PSI]

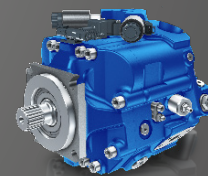

**AddiFlow control valve**

The AddiFlow control valve ensures the safety and management of the activation, release and free-wheeling of MF motors



**SD-CT200 ECU and embedded software**

The ECU manages communication and additional functions

- Automotive standards / IP67 Protection
- Compatible with the CAN truck network

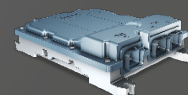

# CBI (USA) Log & Stump Screw

Poclain Hydraulics recently worked with CBI, a part of Terex Ecotec, on the CBI Log & Stump Screw.

The CBI Log & Stump Screw is an attachment for splitting over-sized butt logs, pole wood, tree service block wood and stumps into more manageable sizes that can easily be further processed into firewood, wood fuel or other end products including wood chips.

CBI chose Poclain Hydraulics' 94 hp MSE-18 high-torque spline shaft motor to power the splitter. The motor was chosen thanks to its extreme durability, and simplified assembly.

No additional bearings are needed as the motor carries the entire load attached directly to the screw mechanism. In this manner, all the forces are able to be transferred directly from the screw mechanism to the motor allowing for a simplified assembly. The functionally superior 94 hp MSE-18 is equipped with custom options to increase maximum speeds, lengthen motor lifetime, reduce pressure drops, and ensure safe startups in the harshest climates. The motor is supplied with an integral relief package to prevent failures due to over pressuring of the motor in the demanding conditions the product is used.

"The quality and dependability of Poclain motors is second to none," said Jeff Moulton, director of engineering and aftermarket at CBI. "They were devoted towards this design and dedicated their engineering resources to analyzing our setup and confirming the motor was sized properly for the application. The high pressure allows us to take advantage of the higher pressure settings on newer excavators and maximize our torque output."

The CBI Log & Stump Screw has options for large and small equipment, as the output torque can be sized to accommodate smaller and larger machines. The 94 hp MSE-18 motor in the CBI Log & Stump Screw not only allows for operation at extremely high pressures of up to 5,800 PSI (400 bar), but also allows for the versatility to turn the pressure down and flow up to get larger jobs done faster. The simplified design of the attachment also reduces the need for maintenance passing additional benefit on to the end user.



When asked about the benefits of the Log & Stump Screw, a current user, David Happ of Marquis Tree Service shared, "It's a small unit on a very small excavator but I've been pretty impressed with the size of material it's been able to produce," Happ said. "We've been able to crack beech logs up to sixty, seventy

inches. We've been able to reduce everything that we brought into our yard into manageable debris that we can actually either sell or dispose of at a lower cost."

"For the money, I don't think it could be beat," Happ said. "I don't think you could touch it for any other machine that could reduce wood of the same diameter. Especially with the size constraints we have at our yard. We're running thirty guys out of one acre including material, so we don't have space to put massive material in here or lots of equipment, and we can't afford to store much material on site because of that reason. So to put it on a mini excavator that only weighs 15,000-pounds is a pretty nice option."





**94 hp MSE-18**  
equips the CBI log & stump  
screw

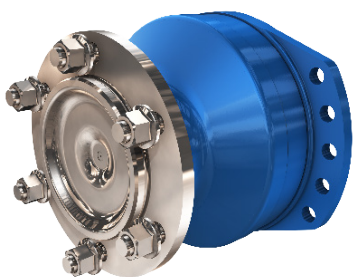

One example Happ gave was a 12,000-pound, 70-inch log they put on the deck of a log truck with a crane and unloaded in the yard — he was able to crack it with the Log & Stump Screw and send it through a 20-inch chipper. “It’s nice to see they overbuilt the options,” Happ said. “Everything is very large steel, I don’t think we’re going to break anything on this unit anytime soon.”

“The versatility of the machine with the screw on it was great because it takes us about ten minutes to swap it over to a different attachment, it’s not a dedicated machine,” Happ explained. “It really didn’t take anything other than running a dedicated case drain line — the install was pretty seamless. Everything matched up perfectly from the factory to the machine based on the specs of the machine so it allows us to have versatility of using one machine to do multiple tasks.”

**“The versatility of the machine with the screw on it was great because it takes us about ten minutes to swap it over to a different attachment, it’s not a dedicated machine”**

# IWAFUJI INDUSTRIAL Co., Ltd

## High Flow MS Motors

Iwafuji Industrial Co., Ltd is a Japanese Company located in the city of Oshu (prefecture of Iwate) that dedicates itself to designing, manufacturing and selling forestry equipment.

Before becoming Iwafuji in 1950, the Company was known by the name Nakajima Aircraft and manufactured both the Hayabusa and Hayate fighters and also engines for airplanes. The Company moved to the forestry equipment activity thanks to Yasushi Koyama, an aircraft engineer who saw the need for a national forestry equipment producer.



**TWO MS05 HIGH FLOW MOTORS AND PM10 PUMP equip the BCR-130B**

Iwafuji is the only company in Japan that offers the market a complete and essential range of forestry equipment. It delivers excellent performance by improving the operation efficiency and lightening the load on the operator. Equipment includes: feller bunchers, skidders, processors, harvesters, swing yarders, tower yarders, and forwarders amongst others.

The first cooperation with Poclairn Hydraulics started in 1992, when Iwafuji developed the T-40TY, a high performance tower yarder equipped with the MS18 motors to drive the winches. The Poclairn Hydraulics motors were chosen for a number of reasons including their ability to rotate at very low and stable speeds, the high torque and the power they provide. However, the main reason they were chosen is the motor's ability to free-wheel.

Pulling the wire cable between the mountains used to be extremely hard work, but by free-wheeling the motors, it became an easier task. 25 years later, IWAFUJI is manufacturing the 5th generation of tower yarders, the TY-U3B. Even after having gone through many different

model iterations, the MS18 motor is still equipping the winches.

In order to improve performance of their excavator-based range of swing yarder, the SW-302 was developed and placed on the market in 2016. By selecting the MS11 motor, the objective of the project team in charge of developing this model was to give to the operator the physical sensation that performances were increased by 15% when compared to the previous generation. The main challenge in developing a swing yarder is in ensuring consistent wire tension. This is done by controlling the two MS11 motors that are driving the 2 winches through the excavator open-loop at the same time.

Iwafuji designed a new and dedicated open-loop circuit to control the MS motors. The high technical ability and long experience of its designers enabled perfect control of the MS motors on the swing yarder—a key factor for Iwafuji's success in the development of its products.

When it comes to performance improvement of forestry equipment, cost reductions and performance, improvements from the engines and actuators are key.

Nowadays, electronic control is becoming a more common way to control the engine and the hydraulic actuators.

30 years after having developed the first model, the new Radio Control Carriage, the BCR-130B entered the market in 2017.



The BCR-130B is installed on a wire fixed between the mountains. By remote control, The BCR-130B is able to pick up and set down trees as well as carry them along the wire. A PM10 tandem pump and high flow version MS05 motors are used to drive the lifting winch and to enable the movement along the wire.

Compared to the previous model, productivity was increased by 80%. All controls are electronic. The “automotive control” was developed internally by Iwafuji. Beyond the performance improvement, an additional feature enables the carriage to stop automatically at any location on the wire. Thanks to this feature, the operator no longer needs to worry about an accident due to an overrun of the carriage. The operator can focus on his work.

The Government would like to increase the national self-sufficiency for wood material from 30% today up to 50% in 2025. However, manpower in this sector is decreasing. Imported wood material is causing fierce price competition. Therefore there will be a growing demand for high performance forestry equipment that reduces the need for manual labor as well as the production cost. The new swing yarder SW-302 and the new radio control carriage BCR-130B are good examples of Iwafuji high performance machines that will continue to drive the high demand for Iwafuji equipment as well as impress end users. Through its highly technical expertise, Iwafuji continuously improves its machines and contributes to national production of timber as a leading company in the forestry market.

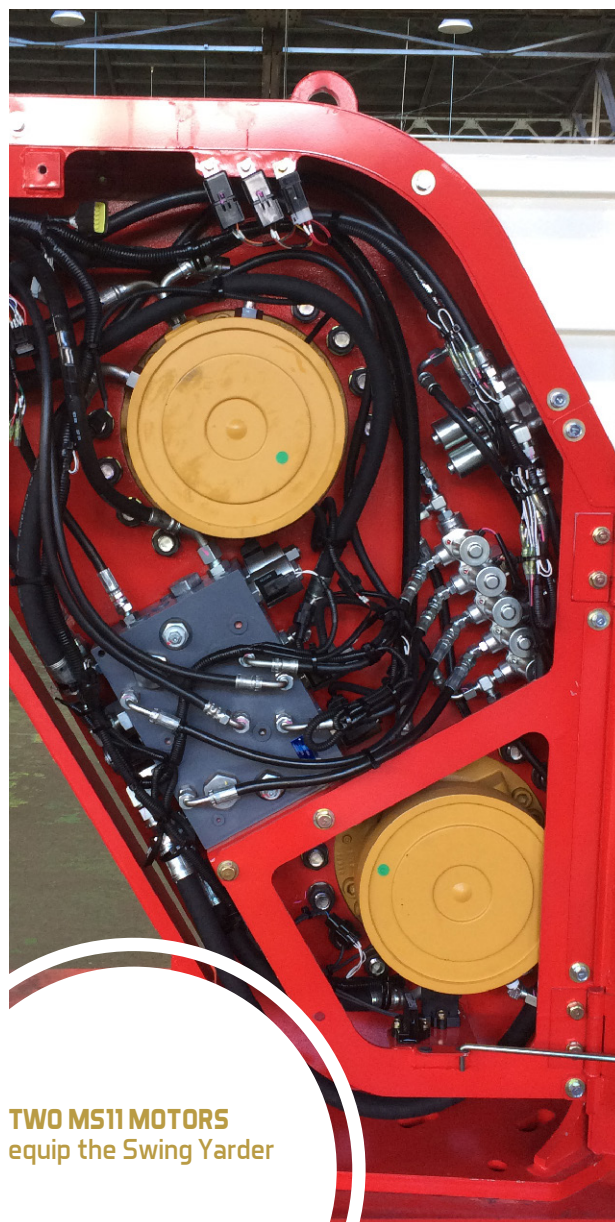

**TWO MS11 MOTORS**  
equip the Swing Yarder

**“The Poclain Hydraulics motors were chosen for a number of reasons including their ability to rotate at very low and stable speeds, the high torque and the power they provide. However, the main reason they were chosen is the motor’s ability to free-wheel.”**

# SEIK Srl Winch Motorization

Seik Srl, located in the wonderful landscape of South Tyrol in Italy, was established in 1991 as a company specialising in mechanical engineering and production.



Seik also specialises in the planning and production of material ropeways that can cope with extreme slopes, narrow ravines, cable lengths of several kilometres and operational areas of over 100.000 square meters.

Since their inception, Seik chose Poclain Hydraulics as a partner for winch motorization, supplied through our distributor in Italy, Promatec Spa.

Poclain Hydraulics' motors were chosen for their ability to deliver the necessary features in areas such as compactness, weight reduction and torque.

Seik outfits its machines with either the MS08 or MS18 range, according to winch size and load, taking advantage of a "short wheel" configuration to save precious space and weight.

Seik also uses the powerful F09/F19 negative brake to handle emergency situations.

Their most recent machine fits a custom MSE08 with dual displacement, high speed internal valving, T09 brake and TD tachymetric sensor for speed and rotation sense signals.

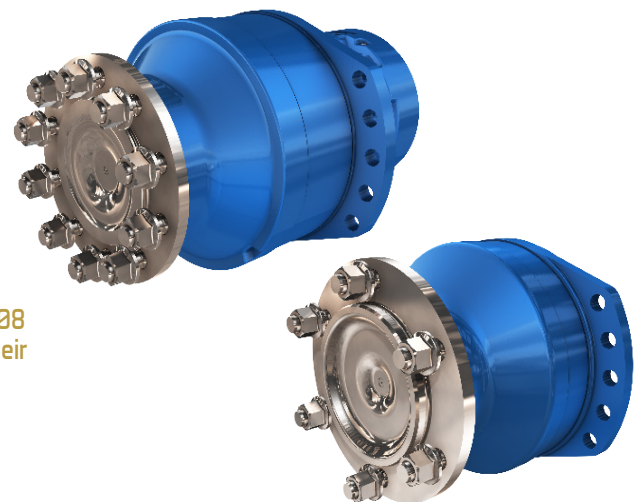

**SEIK'S WINCHES**  
are equipped with MSE08  
or MSE18 according to their  
size and load



# TAJFUN

## A Compact Solution For The MOZ Tower Yarder

Tajfun is a Slovenian company and it is a worldwide leader in forestry attachments with several innovative solutions for logging winches, firewood processors etc. and more recently the mobile tower yarder MOZ. Tajfun has a long history of agricultural and slightly more recently of forestry machines.

The name Tajfun comes from their first machine named Tajfun from 1960s, a hay blower. (Tajfun means typhoon in English). The company was founded by Mr. Jože Špan and is today lead by his son Mr. Iztok Špan. This year, the company celebrates its 50th anniversary.

The MOZ tower yarder is today one of the most efficient systems for wood cable logging with several advantages. The first being it's modern and compact construction. Another advantage is its outstanding mobility, ensuring fast and easy installation and start up in a new location. The machine can follow the tractor wherever the tractor is capable of operating and the capacity is still comparable with big truck mounted yarders. The machine has a large work area, high productivity, safe operation, and offers remote control with one or several remote transmitters. MOZ also boasts a full hydraulic drive with closed-loop hydraulic system, and last but not least, it is more eco-friendly with less damage to the forestry vegetation.

Tajfun and Poclairn Hydraulics have developed this modern and compact solution together based on direct driven winches with high torque MS radial piston motors, new PM50 closed-loop pump, power transmission valves and open-loop valves for auxiliary functions. The main challenge was to design the control of synchronized operation of two winches at the same time (one winch for lifting log and one winch for trolley travel).

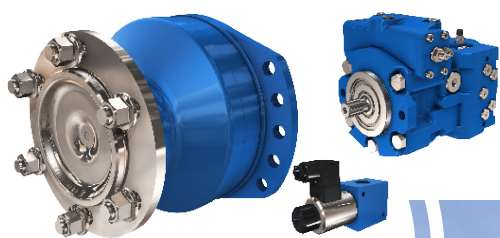

**THE MOBILE TOWER YARDER MOZ300** is equipped with a Poclairn Hydraulics compact solution





# ECO LOG

## A High Performing Travel Drive For Harvesters

---

Eco Log is a manufacturer of Forestry Machines that offers world class products to markets such as Sweden, Germany and France amongst others.

The company is the result of an acquisition of Caterpillar's cut-to-length product line, in February 2004.

The head office is located in Söderhamn, Sweden which houses the management, R&D, marketing, production and spare parts departments.

With great experience in the forestry business and a strong quality awareness, Poclain and Eco Log have worked in close cooperation in order to give the market a reliable transmission for Eco Log Harvesters that is able to withstand their demanding environment.

**ECO LOG HARVESTER**  
is equipped with MS50,  
MSE08, MSE05 motors  
and VDF-H25 valve





## Travel Drive

The ground transmission of an Eco Log harvester is closed loop with an MSE08 hydrobase at each front bogie that together with the MS50 motors in the rear wheels provides enough torque to handle even the most critical climbing in rough terrains.

In order to handle speed shifting the Poclain Hydraulics VDF-H25 valve controls the freewheeling of the MSE08 in the bogies. The integrated 2-speed valve in the MS50 allows for the ability to shift displacement of the MS50 from 5 758 cc to 3 006 cc.

This means that with three gears the machine is able to utilize the full torque in the demanding harvesting application as well as utilize speed in transportation mode.

The cam-lobe motor is a concept that fits well in the design of the Eco Log harvesters where pendulum arms demand a compact design with the possibility to utilize the full torque created by the concept.

## Swing drive

The Eco Log harvesters are equipped with a swing drive where the crane as well as the cabin is mounted on a slew ring driven by two Poclain Hydraulics MSE05s. The cam-lobe concept is beneficial at the swing drive since the direct drive has high efficiency, a low level of high frequency sound emissions and no backlash. This delivers fuel savings as well as a better experience for the driver.

The compact design of the motor allows for ease of integration of the motor under the cabin.

Moving forward, Eco Log and Poclain Hydraulics will continue to deliver reliable solutions for forestry applications.



# CAM-LOBE MOTORS

## THE Solution For Slewing Drives

In early 1950's the French company Poclain created the first hydraulic excavator able to rotate the cabin 360°. This was the first application of the Poclain cam-lobe motor. Since 1958, Poclain, today known as Poclain Hydraulics, has manufactured more than three million cam-lobe motors for different applications globally, including slewing drives for several different machines, forestry harvester cranes being one of the most successful applications.



One of the most important benefits of using Poclain Hydraulics direct drive technology is the compact design, which gives more freedom for machine designers. For example, shorter motor length allows for optimization of the height of the cabin and lowering of the center of gravity of the machine. A design where cabin is directly mounted on the crane is also ergonomic since high frequency noise naturally born from gearbox is not present in cam-lobe direct-drive technology.

Machine owners benefit from fuel savings due to increased efficiency compared to indirect drive solutions where a gearbox is driven by hydraulic motor. They also benefit from reduced service costs since direct drive is not a service point as only one single oil is used for the full hydraulic system. Usage of a slewing drive with direct drive technology delivers added operator comfort with the elimination of high frequency noise and the backlash/drift-free design that comes with the absence of gears clearances. This results in a feeling of high swing reactivity for the machine operator.

A very high volumetric efficiency also ensures smooth movement and high position accuracy of the crane. The limited number of moving parts in the direct swing drive guarantees reliable and safe operation. The drive's long lifetime means high profitability and helps reduce the total cost of the ownership of the machine.

From the very beginning, cam-lobe technology based slewing drives were used in excavators. Since then this technology has been adopted by different applications including forestry cranes.

Poclain Hydraulics has supplied its slewing drive technology for more than ten years to many OEMs including many of the biggest forestry machine manufacturers.

Direct drive solutions are used in machines where the cabin is directly mounted on the crane as well as in machines where crane and cabin are mounted separately.



# DIRKER

## A Complete Drive System For The 2DLH Log Handler

The company - Forkliftmaster (Pty) Ltd was established in Pretoria, South Africa in 2006, and in 2007, Jaco Dirker and his wife Gwen took over management of the company. The company initially offered only forklift rentals and trading of second hand forklifts. However, in 2012 the opportunity arose to start developing and manufacturing their own forklift brand called 'Dirker' and in 2013 the first Dirker rough terrain forklift was assembled, tested and sold. Production of the forklifts grew steadily with six machines sold in 2014 - of which one machine was exported to neighboring Zimbabwe.

Originally, the Dirker rough terrain forklifts were developed mainly for use in brickyards, but in 2015 the first Dirker Log Handler was built, and the company entered the forestry materials handling market in Southern Africa. That same year, they also built a new manufacturing facility and a total of 12 machines were sold.

During this time, Poclain Hydraulics South Africa approached Jaco Dirker with a proposal to use its MSE18 motors and PM50 tandem pump as the drive system for the three-wheeled Log Handler machine, and the proposal was accepted in early 2016, with the first prototype machine built and commissioned in July 2016.

The Dirker log handler is a three-wheeled machine fitted with a 0.35 m<sup>3</sup> log grapple, of which the two front wheels are driven and used to steer the machine via two foot pedals. This configuration leaves the operator's hands free to use the hydraulic valve levers in the cab

to operate the log grapple and boom functions. The 4t machine has a 49 kW air cooled engine installed, which drives two MSE18 motors (2 808 cc displacement each) via a PM50 tandem pump (45 cc + 45 cc). The tandem pumps are hydraulically and individually piloted via two foot pedals. The two motors are also equipped with the F12 parking/emergency brake.

According to Jaco Dirker, the machine with a full Poclain Hydraulics drive system has performed exceptionally well, and he is very pleased with it.

Forklift master is currently expanding its own dealer network in South Africa and has also signed a distributor agreement with another forestry and construction equipment supplier in order to increase sales of their products countrywide. The next step will be to export this machine internationally.



**THE DIRKER 2DLH LOG HANDLER** is equipped with two MSE18 and PM50 in tandem

# HITTNER Skidder Brake Valves

Hittner is a long-standing Croatian company that historically has specialized in forestry skidders. In addition to these machines Hittner has become more and more involved in smaller agricultural tractors as well as a wide range of tractor attachments.

Hittner has grown from the maintenance service in the late 1980s to the OEM design and production of the EcoTrac skidder at the beginning of the new millennium. The company has been known under the brand-name Hittner since 2004 (named after the founder and the owner Mr. Hittner). For several years in a row Hittner has been included among the best private companies in Croatia.

The collaboration between Hittner and Poclain Hydraulics started recently when we proposed to Hittner the power braking valves as a more efficient and brake-saving solution when compared to the mechanical counterpart. The full brake solution includes

the VB-22E brake valve combining actuation of a dynamic positive brake HASR (Hydraulic Applied Spring Released) and of a negative electric parking/emergency brake SAHR (Spring Applied, Hydraulic Released) and the accumulator charging function. VB-22E is the most sophisticated valve combining all braking functions required by the majority of agricultural and construction off-road vehicles.

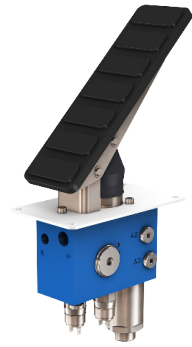

**VB-22E VALVE**  
combines the actuation of a dynamic positive brake and of a negative electric parking/emergency brake





# Poclain Hydraulics Sales Subsidiaries In The World

## BRAZIL

POCLAIN HYDRAULICS LATIN AMERICA  
Rua Francisco Leitão,  
469 Conj. 1508 - Pinheiros  
CEP 05414-020 São Paulo  
Tel. : +55 11 2615 8040

## CHINA

POCLAIN HYDRAULICS CN  
Room 606  
Block A of Building one  
Quanshitiandi Plaza  
No. A50 Wangjing West Road  
Chaoyang District  
Beijing, Post code: 100102  
Tel. : +86.10.64.38.66.18

POCLAIN HYDRAULICS CO, LTD  
Factory Building n° 11, Phase II Shuhui  
Park N° 275  
Qianpu Road, Songjiang District  
Shanghai 201611  
Tel. : +86 21 37 00 34 15

## CZECH REPUBLIC

POCLAIN HYDRAULICS SRO  
Ksirova 186,  
CZ 619 000 Brno - Horni Hespice  
Tel. : +420 543 563 111

## FINLAND

POCLAIN HYDRAULICS OY  
Vernissakatu 6  
01300 Vantaa

## FRANCE

POCLAIN HYDRAULICS FRANCE SAS  
Route de Compiègne  
60410 Verberie  
Tel. : 03 44 40 78 64  
03 44 40 79 66

POCLAIN HYDRAULICS FRANCE NANTES  
57, rue des Vignerons  
44220 Couëron  
Tel. : 02 40 85 52 52

POCLAIN HYDRAULICS FRANCE LYON  
58, avenue Chanoine Cartellier  
Le Cleveland III  
Z.A. Les Basses Barolles  
69230 Saint Genis Laval  
Tel. : 04 78 56 67 44

## GERMANY

POCLAIN HYDRAULICS GMBH  
Werner-von-Siemens-Str. 35  
64319 Pfungstadt  
Tel. : +49 6157 / 9474-0

## INDIA

POCLAIN HYDRAULICS PVT. LIMITED  
3rd Floor, No 52, Agastya Arcade  
80 Feet Road, Opposite MSR Hospital  
Bengaluru 560 094  
Tel. : +91 80 4110 4499  
+91 80 23417444

## ITALY

POCLAIN HYDRAULICS SRL  
Via Remesina int, 190  
41012 Carpi (Modena)  
Tel. : +39 059 655 0528

## JAPAN

POCLAIN HYDRAULICS KK  
4-2, Miyoshi cho, Naka ku,  
Yokohama, Kanagawa 231-0034  
Tel. : +81-45-341-4420

POCLAIN HYDRAULICS KK  
#709, in Toyo Building,  
3-2-5, Hachiman-dori,  
Chuo-ku, Kobe-shi, Hyogo-ken,  
651-0085  
Tel: +81 78 891 4446

## KOREA

POCLAIN HYDRAULICS YH  
#104-1010 Sindorim Prugio  
337 Sindorim-dong, Guro-gu,  
Séoul, 152-748  
Tel. : +82 2 3439 7680

## NETHERLANDS

POCLAIN HYDRAULICS BENELUX BV  
Florijnstraat 9  
4879 AH Etten-Leur  
Tel. : +31 76 502 1152

## RUSSIAN FEDERATION

POCLAIN RUS, LLC  
Novaya Basmannaya street, 28,  
building 2, office 12  
105066 Moscow  
Tel. : +7 (495) 105 9301

## SINGAPORE

POCLAIN HYDRAULICS PTE LTD  
10 Anson Road  
#35 - 10 International Plaza,  
079903  
Tel. : +65 6220 1705

## SLOVENIA

POCLAIN HYDRAULICS DOO  
Industrijska ulica 2  
SI-4226 Ziri  
Tel. : +386 (0)4 51 59 100

## SOUTH AFRICA

Jan Lotz-PO Box 1272  
Ballito, KZN  
Tel. : +27 82 300 0584

## SPAIN

POCLAIN HYDRAULICS SL  
C/ Isaac Peral n°8-10, Local n°3  
08960 - Sant Just Desvern (Barcelona)  
Tel. : +34 934 095 454

## SWEDEN

POCLAIN HYDRAULICS AB  
Sjöängsvägen 10  
19272 Sollentuna  
Tel. : +46 8 590 88 050

## THAILAND

POCLAIN HYDRAULICS PTE LTD  
2/51 BangNa Complex ; 11th Floor, Tho-  
sapol Land Building 4  
Soi Banga Trat 25, Bangna,  
Bangkok 101260  
Tel. : +66 (0) 2173 6026 Ext. 220

## UNITED KINGDOM

POCLAIN HYDRAULICS LTD  
Nene Valley Business Park  
Oundle, Peterborough, Cambs PE8 4HN  
Tel. : +44 183 227 3773

## USA

POCLAIN HYDRAULICS INC  
1300 N. Grandview Parkway  
PO BOX 801 WI  
53177 Sturtevant  
Tel. : +1.262.321.0676 5720/5721

## More than 150 distributors in the world

To find the nearest distributor go to our dedicated web page  
[www.poclain-hydraulics.com/en/contact-us/distributors](http://www.poclain-hydraulics.com/en/contact-us/distributors)





World Leading Specialist In Hydrostatic Transmissions



[www.poclain-hydraulics.com](http://www.poclain-hydraulics.com)

